

## Finite Element Analysis of Single Lap Adhesive Joint Using RADIOSS

M. S. Kadam<sup>1</sup>, Pankaj Firake<sup>2</sup>, K. K. Pawar<sup>3</sup>

<sup>1</sup>(Mechanical, JSPM's Rajarshi Shahu College Of Engineering, Pune, India)

<sup>2</sup>(Mechanical, JSPM's Rajarshi Shahu College Of Engineering, Pune, India)

<sup>3</sup>(PG Scholar, IITM, Chennai, India)

---

**Abstract:** Majority of automobile and aerospace parts, mainly their body components are joined together by different types of adhesives. So these growing needs demand the detailed study on stress concentration and strength analysis of adhesive joints. With the help of structural analysis simulations we can identify the problem areas, failure loads and solutions can be validated in computers without any expensive shop floor operations prior to any tool construction. Structural analysis simulation is also helpful at the joint design stage to decide various parameters, like thickness, overlap length etc. In the recent years the use of finite element analysis is increased in the strength analysis of sheet metal joints. Finite element analysis helps to analyse the process virtually. The present investigation reports a case study of a single lap adhesive joint of similar metals. This joint is subjected to static tensile loading and the RADIOSS deck of Hyperworks 11.0 software package is used to carry out the analysis. The analysis result helps in depicting the failure loads for different conditions. The effects of varying load and adhesive thickness on stress induced and hence on the joint strength of Aluminium to Aluminium single lap adhesive joint under static tensile loading is studied in this case study.

**Keywords:** Stress concentration, Strength analysis, Single lap adhesive joints and Adhesive thickness.

---

### I. Introduction

The influence of static tensile loading on stress distribution within the adhesive joint is analyzed by finite element method. Practically Von Mises stresses are maximum at edge and decreases away from edge. Similarly shear stresses almost vanish towards the middle of the adhesive. The shear stress contribution to the Von Mises stress is significant in the bond region close to the Aluminium plate; this in turn results in possible failure of bonding in this region. In actual practice strength of adhesion to the metal surface is stronger than the strength of the adhesive itself. That means the joint will fail in midway of adhesive instead of at the adhesive metal interface.

### II. Literature Review

The work of different researchers in the area of strength analysis of single lap adhesive joint is presented below,

Ramazan Kahraman (2008) develops information on the influence of adhesive thickness and aluminum filler content on the mechanical performance of aluminum joints bonded by aluminum powder filled epoxy. The influence of adhesive thickness and aluminum filler content on stress distribution within the adhesive is analyzed by finite element method (FEM). Both FEM analysis and the experimental investigation show that in general adhesion strength decreases as the thickness of the adhesive increases. Experimental results shows that the joints fail in cohesive mode due to the high stress levels generated in the adhesive, which indicates that the adhesion to the metal surface is stronger than that of the interior part of the adhesive.

Jae-Hyun Park (2010) evaluated the strengths of thick aluminum to aluminum joints with different adhesive lengths and thicknesses. A modified version of the damage zone theory is proposed which is based on the yield strain ratio and use this framework to predict failure loads for various adhesive joints. It is concluded that the failure loads of adhesive joints of eight different adhesive lengths increased with the adhesive length, but the adhesive strengths decreased. The failure load of the adhesive joint with a 0.45 mm adhesive thickness exhibited the largest value of the four cases investigated.

Xiacong He (2011) reviewed the recent work relating to finite element analysis of adhesively bonded joints, in terms of static loading analysis, environmental behaviors, fatigue loading analysis and dynamic characteristics of the adhesively bonded joints. It is concluded that the finite element analysis of adhesively bonded joints will help future applications of adhesive bonding by allowing system parameters to be selected to give as large a process window as possible for successful joint manufacture. This will allow many different

designs to be simulated in order to perform a selection of different designs before testing, which would currently take too long to perform or be prohibitively expensive in practice.

Yi Hua (2012) investigated the performance of recessed single-lap joints with dissimilar adherends through the finite element method. The influence of material and geometric nonlinearity of the adhesive as well as the impact of the recess length was examined in terms of maximum principal stresses. The strength of the joint is obtained as the load to initiate the crack propagation. Results suggested that either adding a spew fillet or considering the adhesive plasticity led to reduced peak stresses at the edge of the adhesive layer. Large stresses occurred at the interfaces rather than the middle plane of the adhesive layer, which implied a limitation of analytical solutions.

E. F. Karachalios (2013) analyzed single lap joints in many geometric and material configurations using finite element analysis and tested in tension. The geometric parameters, such as the overlap length and adherend thickness, together with material parameters such as the adherend and adhesive stress strain behavior are also tested. In this paper the high strength steel adherends are considered. For it and a relatively short overlap, failure is dominated by adhesive global yielding. As the overlap gets longer, however failure is no longer due to global yielding, but due to high local shear strains.

Lijuan Liao (2013) analyzed the rupture initiation position, the stress wave propagations and interface stress distributions of the single lap adhesive joint with dissimilar adherends under impact tensile loadings via experiments combined with FEM calculations taking account of the strain rate dependency property of the adhesive. It is obtained that rupture initiates at the interface of the adherend with higher Young's modulus and also found that the strength of the joint with dissimilar adherends is smaller than that of the joint with similar adherends when the joint is subjected to the impact tensile loading.

The summary of the literature review is presented in the Table No. 01.

**Table No. 01: Literature Review**

Sr. No.	Researcher	Adherent material	Adhesive Material	Method of Analysis			Type of Stresses			
				FE A	Analytical	Experimental	Tensile	Peel	Shear	Clearance
01	Ramazan Kahraman (2008)	Aluminum	two-part epoxy (Fusor 309)	√	-	√	-	-	√	-
02	Jae-Hyun Park (2010)	Al alloy 6061-T6	FM73 M epoxy	√	-	√	√	-	-	-
03	Xiacong He (2011)	Composites	Structural adhesives	√	-	-	-	-	√	-
04	Xiacong He (2012)	Aluminum Alloy	acryloid cement	√	-	√	-	-	-	-
05	Yi Hua (2012)	Carbon/epoxy , titanium	FM73	√	-	-	-	√	√	-
06	E.F. Karachalios (2013)	High Strength steel	Structural adhesive	√	-	√	√	-	-	-
07	Lijuan Liao (2013)	Aluminum, steel	Structural adhesive	√	-	√	√	-	-	-

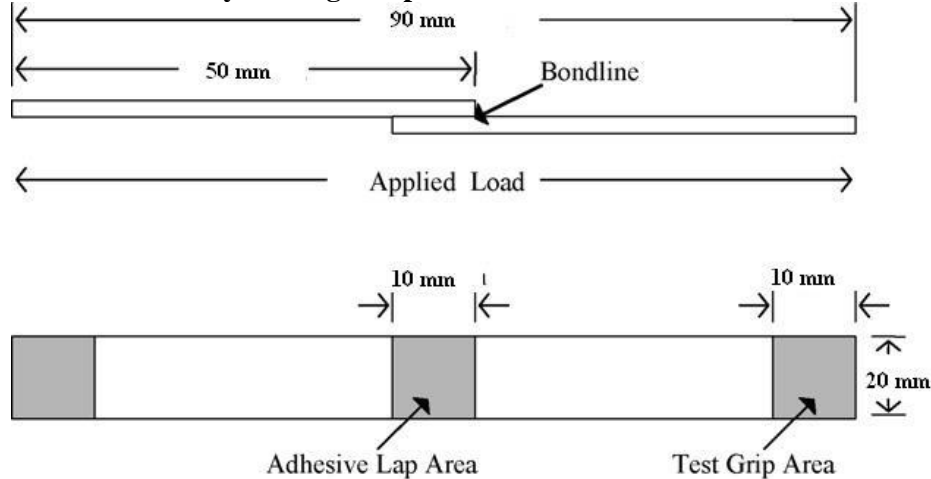
### III. Advantages Of Adhesive Joints

The various types of adhesive joints are widely used now days in automobile and aerospace industries because of its inherent advantages listed below.

- It is lightweight chemical, so reduces weight of the joint as compare to riveted or bolted which adds its self weight to the joint.
- Adhesive joining techniques do not require holes, as riveted or bolted joints do, which can lead to stress concentration.
- Adhesives are compressible in nature which helps to damp the vibrations generated at high speed.

- Different types of adhesives for different applications are available commercially at very low cost.
- Some special types of adhesives are able to sustain at very high temperature and varying environmental conditions.

#### IV. A Case Study Of Single Lap Aluminium To Aluminium Adhesive Joint



**Fig. 01: Single-lap shear joint configuration.**

Fig.01 shows the single lap shear joint configuration used for the strength analysis in simulation with RADIOSS. The Structural Epoxy Adhesive is used to join two Aluminium Plates. The material properties of the metal plates i.e. Aluminium and of the adhesive used i.e. Structural Epoxy are as shown in Table No. 02.

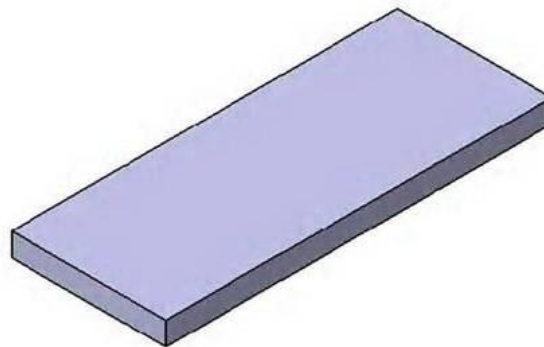
**Table No.02: Material Properties**

Material Used	Modulus of Elasticity (E) in MPa	Poisson's Ratio ( $\nu$ )
Aluminium	6.8950e4	0.333
Structural Epoxy	1.0858e3	0.380

Following is the detailed procedure adopted for the Finite Element Analysis.

##### IV.1 Creating the 3D model:

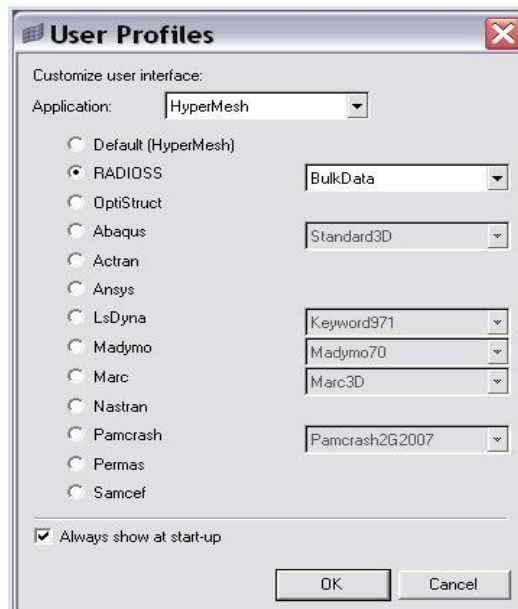
3D model of the component is created in CATIA V5 R16 as shown in Fig. 02. The model is created in two easy steps. First one plate is created and assigns Aluminium material to it. Then create the second plate and assign the Aluminium material to it.



**Fig. 02: 3D model of the component.**

#### **IV.2 HyperMesh 11.0 is opened in user profile:**

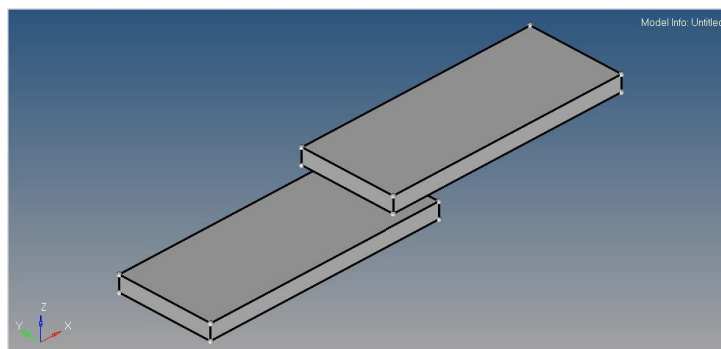
To open **RADIOSS**, click Start then **HyperMesh**. A User Profiles window should pop up, as shown in Fig.03. If the User Profiles window doesn't pop up go to Preferences then click on User Profiles. Under the Application drop down list select **HyperMesh**, select **RADIOSS Bulk Data** deck and click on OK.



**Fig. 03: User Profile**

#### **IV.3 The 3D model is imported in HyperMesh:**

To import 3D model, go to File and click on Import. Then for the Import Type choose Geometry and for the File type choose Auto Detect. Then click the yellow folder icon and browse to where the CatPart file is located and click on Import then Close. The imported geometry i.e. two plates will look as shown in Fig.04.



**Fig. 04: Imported 3D model of the metal plates**

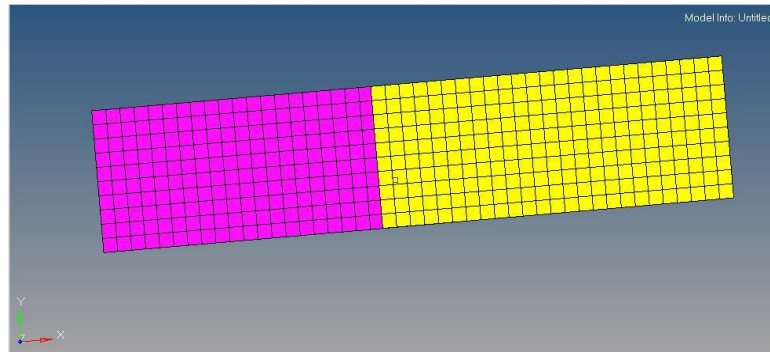
#### **IV.4 Mesh The Plates:**

To mesh the plates, after clean up the geometry, mesh both plates one by one. Enter the following values.

Element Size: 2

Mesh Type: quads

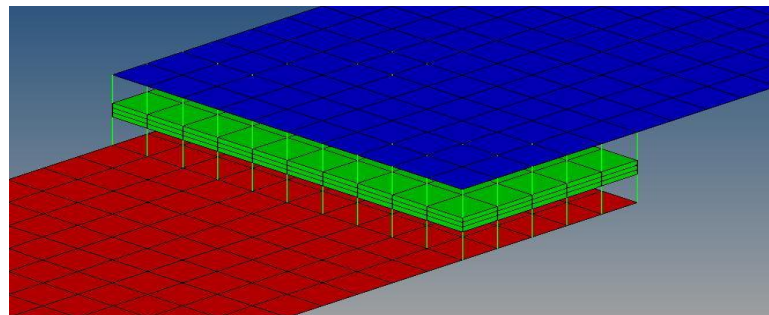
Click on mesh button. A uniform mesh will be generated. The meshed component will be as shown in Fig. 05.



**Fig. 05: Meshed Plates**

#### IV.5 Create Adhesive Connector:

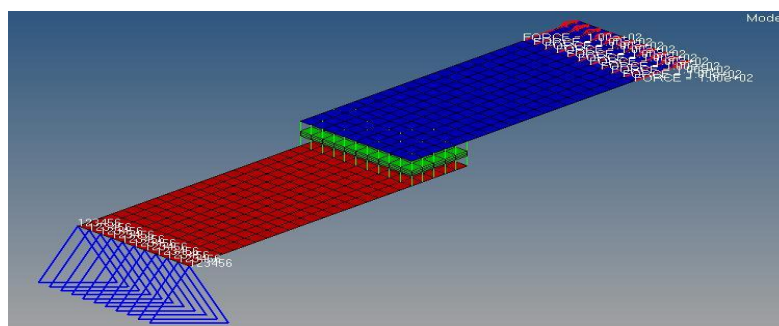
For creating adhesive first of all hide one meshed plate then select some of the elements on bottom plate. Then click on elems and select by adjacent to select required row of elements to join. For components click on comps and select Al\_Plate\_01 and Al\_Plate\_02. In type of connector select adhesives and enter the value of density as 3 under  $(T1+T2)/2$  option with tolerance of 10. An adhesive will be generated between these two plates as shown in Fig. 06.



**Fig. 06: Adhesive Connector**

#### IV.6 Apply Boundary Conditions:

Nodes on extreme left edge of the bottom plate are selected, and constrain their all degrees of freedom with a zero value. This constrain comes under SPC load collector. Then select the nodes on extreme right edge of the top plate and apply an axial load on each node in X direction. The model under constraints is shown in Fig. 07.



**Fig. 07: Joint with Boundary Conditions**

#### IV.7 Model is checked and analysis is run:

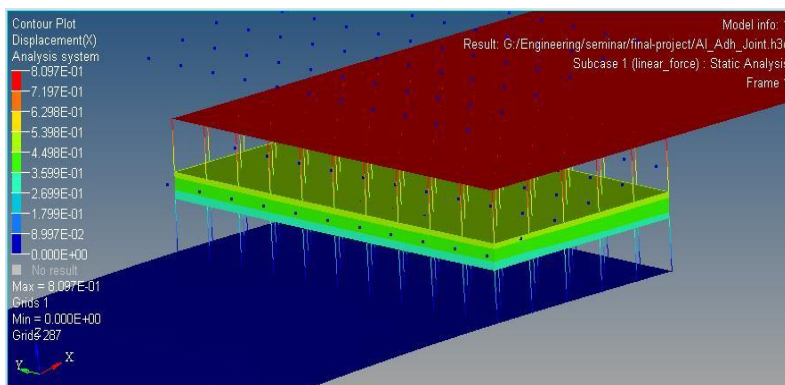
After completing all boundary conditions and applying all loads, click on Analysis tab and save the file as Al\_Adhesive\_Joint.fem and click on Radioss. It will run the solver file and displays that the analysis is completed; the prompt display is shown in Fig.08.

```
*****  
**  
**                               **  
**                               **  
**              RADIOSS 11.0          **  
**                               **  
**      Finite Element Analysis Software  **  
**      from Altair Engineering, Inc.      **  
**                               **  
**      Windows XP Professional SP3 <Build 2600> MAHESH **  
**      2 CPU: AMD C-60 APU with Radeon(tm) HD Graphics **  
**      CPU speed 1000 MHz **  
**      1793 MB RAM, 4095 MB swap **  
** Build tag: 0569254_5333110_Ci32RH11M:61051-000 14000 **  
**                               **  
**      COPYRIGHT (C) 1996-2011          Altair Engineering, Inc. **  
**      ALL RIGHTS RESERVED. Copyright notice does not imply publication. **  
**      Contains trade secrets of Altair Engineering, Inc. **  
**      Decompilation or disassembly of this software strictly prohibited. **  
**      *****  
  
The amount of memory allocated for the run is 41 MB.  
This run will use in-core processing in the solver.  
  
ANALYSIS COMPLETED.
```

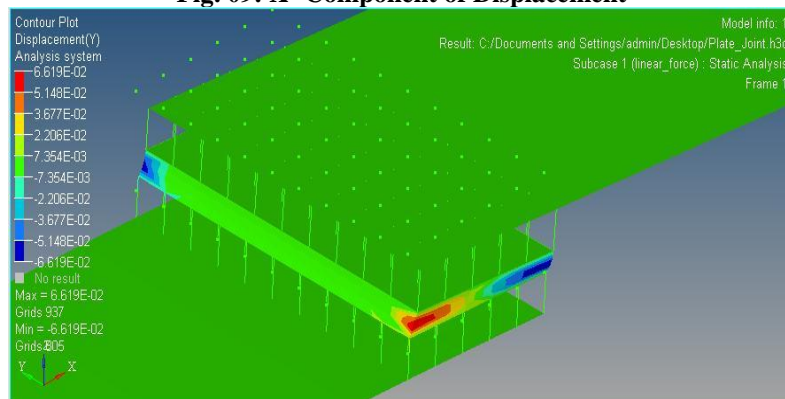
**Fig. 08: Solver Run prompt**

#### IV.8 View the results:

To see the results click on Hyperview in Analysis tab. We will get the required results such as displacements and elemental stresses (Von-Mises stresses and maximum shear stresses) in Hyperview environment.

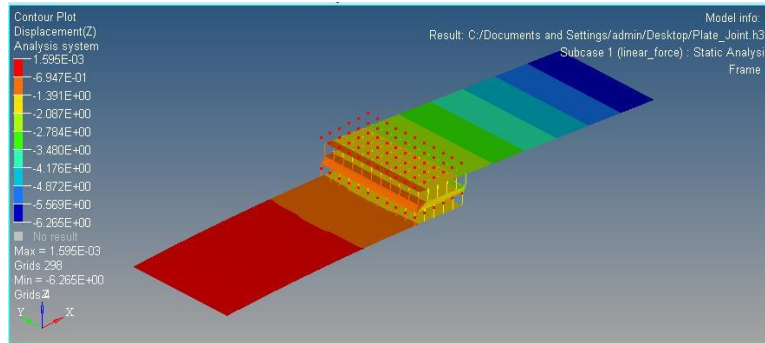


**Fig. 09: X- Component of Displacement**

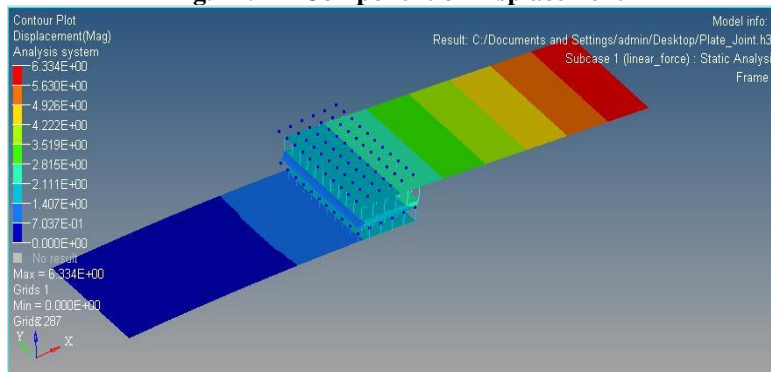


**Fig. 10: Y- Component of Displacement**

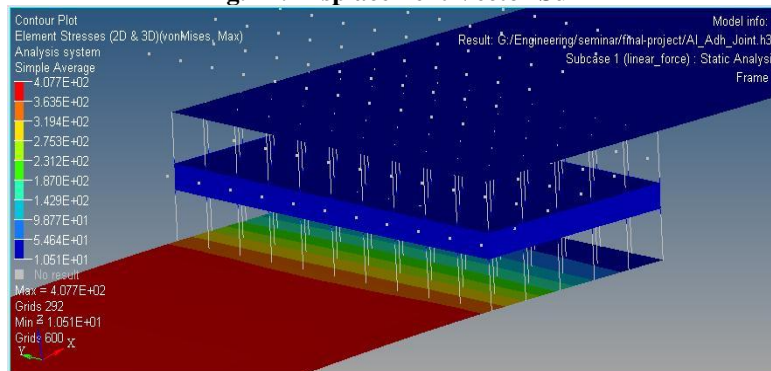
Fig.09, Fig.10 & Fig.11 shows the X, Y and Z components of displacement respectively after application of the load, while Fig.12 shows the displacement vector sum that is magnitude of average displacement of the joint.



**Fig. 11: Z- Component of Displacement**

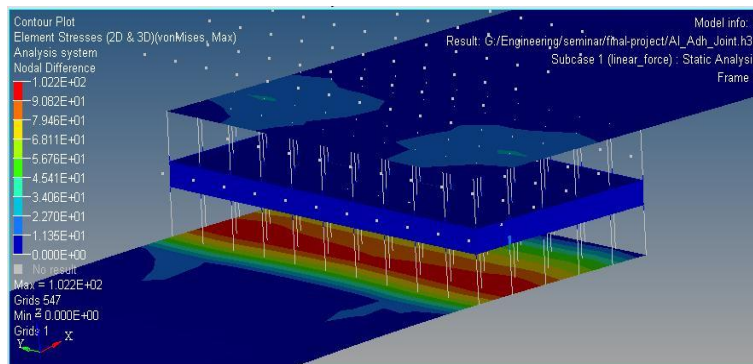


**Fig. 12: Displacement Vector Sum**



**Fig. 13: Simple Von Mises Stresses**

Now following are the images which displaying the results for the elemental stresses obtained at joint consisting of simple Von Mises stresses in Fig. 13 and Difference Von Mises stresses in Fig. 14.



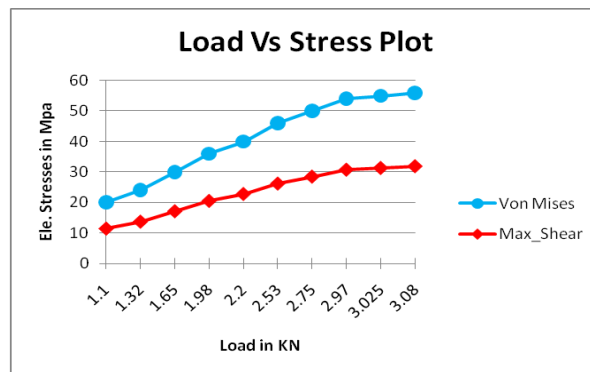
**Fig. 14: Difference Von Mises Stresses**

**V. FEA Results:**

Above procedure is repeated for different loads at adhesive thickness of 2mm and determine the respective stresses. The values obtained by analysis are entered into tabular form as in Table No. 03. The graph showing relation between load applied and stresses induced is shown in Fig.15.

**Table No. 03: Load & Stress Values**

Trial No.	Load Applied	Elemental Stress in MPa	
	in KN	Von Mises	Max Shear
1	1.100	20.01	11.39
2	1.320	24.01	13.66
3	1.650	30.01	17.08
4	1.980	36.01	20.49
5	2.200	40.02	22.77
6	2.530	46.02	26.19
7	2.750	50.02	28.46
8	2.970	54.02	30.74
9	3.025	55.02	31.31
10	3.080	56.02	31.88



**Fig.15 : Load Vs Stress Plot for 2 mm adhesive thickness**

The FEA process is also repeated for different adhesive thicknesses keeping the load applied same and determine the different stress values at this load. The values are entered into a Table No. 04 and plot a graph of thickness Vs stress in Fig.16.

The Epoxy adhesive offers tensile shear strength of 4560 psi i.e. 31.44 MPa. (news.thomasnet.com/fullstory/ @ 1.00 PM on 09.11.2013)

**Table No. 04: Adhesive Thickness & Elemental Stresses**

Trial No.	Adhesive Thickness in mm	Elemental Stress in MPa	
		Von Mises	Max Shear
1	0.5	43.12	24.63
2	1	46.91	26.76
3	1.5	50.89	28.99
4	2	55.02	31.31
5	2.5	59.27	33.69
6	3	63.57	35.94



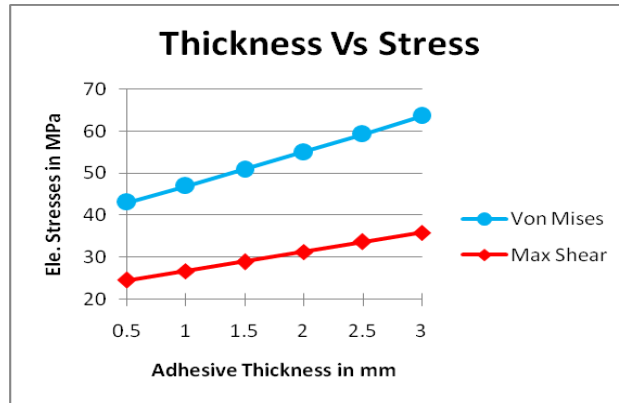


Fig. 16: Thickness Vs Stress Plot

**VI. Comparison with the Experimental Results:**

Finally the FEA results are compared with Experimental results that have been obtained by Mr. Ramazan Kahraman in his research paper as mentioned in reference no. 1. The effect of adhesive thickness on Von Mises Stresses is determined by plotting these values on a graph as shown in Fig.17 and entered in Table No. 05.

Table No. 05: Adhesive Thickness & Von Mises Stresses

Trial No.	Adhesive Thickness in mm	Von Mises Stresses in MPa	
		By FEA	By Exp.
1	0.2	17.26	20.30
2	0.4	18.69	20.80
3	0.6	20.15	21.10
4	0.8	21.63	22.30
5	1	23.15	23.20
6	1.2	24.68	24.10

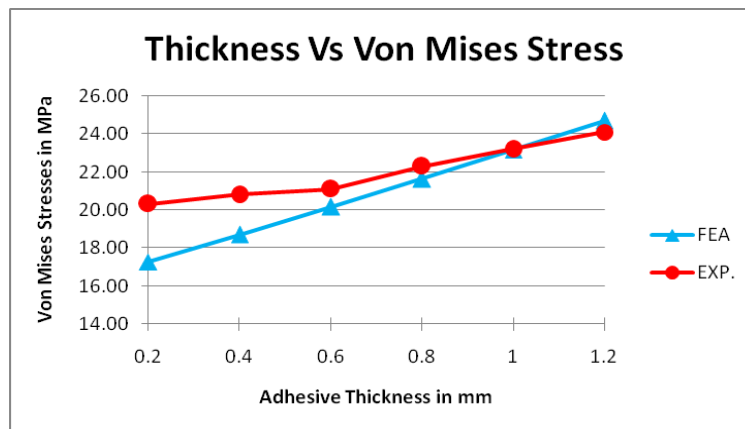
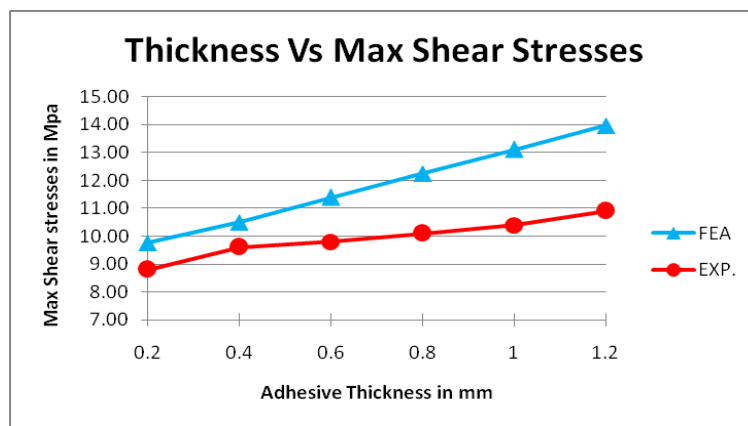


Fig.17: Adhesive Thickness Vs Von Mises Stresses Plot

From above table & graph it is clear that the values of Von Mises stresses obtained by FEA are closely matching with that of obtained by experimental method. At adhesive thickness of 1mm the value of Von Mises stress by FEA is almost equal to the experimental value. Now the values of maximum shear stresses obtained by FEA at these thicknesses are entered into Table No. 06 along with experimental values and plotted the same on a graph as shown in Fig.18.

**Table No. 06: Adhesive Thickness & Max Shear Stresses**

Trial No.	Adhesive Thickness in mm	Max Shear Stresses in MPa	
		By FEA	By Exp.
1	0.2	9.77	8.80
2	0.4	10.50	9.60
3	0.6	11.40	9.80
4	0.8	12.25	10.10
5	1	13.11	10.40
6	1.2	13.97	10.90



**Fig.18: Adhesive Thickness Vs Max Shear Stress Plot**

## VII. Conclusions

Following conclusions are drawn from the analysis of the case study.

1. It is found from the analysis that, for the same adhesive thickness and material properties the stress induced is directly proportional to the load applied.
2. As stress induced has negative effect on the joint strength, the strength of the joint is decreased with the increase in the adhesive thickness.
3. It is observed that the finite element predictions for Von Mises stresses agree well with the experimental results.
4. There are some discrepancies in the values of maximum shear stresses obtained by FEA and by experimental method because of experimental errors and assumptions made in the finite element simulations.
5. Even though the finite element analysis shows higher failure stresses at the adhesive to metal substrate interface, actual failure occurs within the adhesive, because same is visualised in EFA results.
6. The Von Mises stresses by FEA agree well with the experimental values at higher thickness than that of lower thickness of adhesive used. Whereas maximum shear stresses by FEA are agree well with the experimental values at lower thickness than that of higher thickness of adhesive used.

## References

- [1]. Ramazan Kahraman, Mehmet Sunar, Bekir Yilbas; "Influence of adhesive thickness and filler content on the mechanical performance of aluminum single-lap joints bonded with aluminum powder filled epoxy adhesive"; *Journal of Materials Processing Technology* 205 (2008) 183–189.
- [2]. Jae-Hyun Park, Jin-Ho Choi, Jin-Hwe Kweon; "Evaluating the strengths of thick aluminum-to-aluminum joints with different adhesive lengths and thicknesses"; *Composite Structures* 92 (2010) 2226–2235.
- [3]. Xiaocong He; "Numerical and experimental investigations of the dynamic response of bonded beams with a single-lap joint"; *International Journal of Adhesion & Adhesives* 37 (2012) 79–85.
- [4]. Xiaocong He; "A review of finite element analysis of adhesively bonded joints"; *International Journal of Adhesion & Adhesives* 31 (2011) 248–264.

- [5]. Yi Hua, Linxia Gu, Michael Trogdon; “Three-dimensional modeling of carbon /epoxy to titanium single-lap joints with variable adhesive recess length”; *International Journal of Adhesion & Adhesives* 38 (2012) 25–30.
- [6]. E.F. Karachalios, R. D. Adams, Lucas F.M. da Silva; “Single lap joints loaded in tension with high strength steel adherends”; ”; *International Journal of Adhesion & Adhesives* 46 (2013) 81–95.
- [7]. Lijuan Liao, Toshiyuki sawa, Chenguang Huang; “Experimental and FEM studies on mechanical properties of single-lap adhesive joint with dis-similar adherends subjected to impact tensile loading”; *International Journal of Adhesion & Adhesives* 47 (2013) 91–98.